

Dismantling Joints NP16

Specifications

Working Pressure-	16 bar
Test Pressure-	24 bar
Pipe O/D's-	See below
Notching-	See below

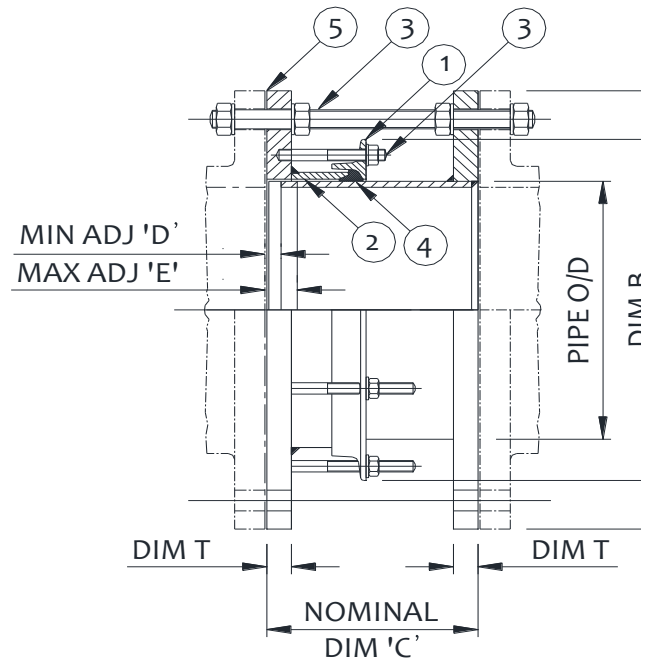

Materials

End Rings-	1. Mild Steel to BS EN10025
Sleeves-	2. Mild Steel to BS EN10025
Bolts/Studs-	3. Grade 8.8 / B7 Galvanized
Gaskets-	4. EPDM rubber 70 IRHD
Flanges-	5. Mild Steel to BS EN10025
Coating-	Fusion Bonded Epoxy - Resicoat R4

Nom Size	Flange O/D Dim A	Flange Thk Dim T	End Ring Dim B	Overall minimum Dim C	Adjustment		No of Tie Rods	Tie Rod Dia / Length	No of Notches	No of Bolts
					Min D	Max E				
300	460	25	418	300	25	50	4	M24 x 460	4	6
350	520	25	450	300	25	50	4	M24 x 460	4	8
400	580	25	500	300	25	50	4	M27 x 470	4	8
450	640	25	551	300	25	50	5	M27 x 470	-	10
500	715	25	602	300	25	50	5	M30 x 480	-	10
600	840	25	704	300	25	50	5	M33 x 500	-	10
700	910	25	805	300	25	50	6	M33 x 520	-	12
800	1025	25	907	300	25	50	6	M36 x 540	-	12
900	1125	25	1008	300	25	50	7	M36 x 560	-	14
1000	1255	25	1132	300	25	50	7	M39 x 580	-	14
1100	1355	25	1234	300	25	50	8	M39 x 590	8	16
1200	1485	38	1335	300	25	50	8	M45 x 620	-	16



Bolt Dia /
Length

M12 x 140

M12 x 140

M12 x 140

M12 x 140

M12 x 140

M12 x 140

M12 x 140

M12 x 140

M12 x 140

M16 x 160

M16 x 160

M16 x 160

